

IRM®- 8 WATERMANAGER

Industrial rainwater system with double pumps and supply pump



rethinking water



PRODUCT DESCRIPTION

The IRM®-8 Watermanager is a plug-in, compact installation for rainwater use in residential complexes, commercial and public buildings. The break tank for drinking water supply conforms to EN1717 type AA, capacity 100 liters. The IRM®-8 Watermanager has a double self-priming centrifugal pump (RC-3 or RC-5). A supply pump serves for the supply of rainwater from the rainwater tank in the break tank. In the absence of rainwater, the break tank is filled with drinking water by means of a 1 "solenoid valve.

The IRM®-8 Watermanager is provided with steel casing and must be installed in a frost-free, dry room with drainage on the ground, for example a scrubbing well. Pressure and status display of the system is clear, in four languages, shown on the LCD display. Control is equipped with a turn-hour control, with data log, and control of the automatic filter cleaner (option).

SCOPE

The system is applicable for the use of filtered rainwater for toilet flushes and other applications for which no drinking water quality is required, within utility buildings and commercial buildings.

TECHNICAL DATA

Width in mm:	570
Depth in mm:	600
Height in mm:	1.313
Weight (empty) in kg.:	90
Weight (full) in kg.:	190
Pressure line:	1 1/2" bu
Drinking water connection:	5/4" bu
Supply pump:	5/4" bu
Emergency overflow in mm:	110

TECHNICAL SPECIFICATIONS

Voltage in V:	230
Power in Watt:	2.200
Max. flow in liters / min:	120
Max. increaseHeight in m:	50
Number of fans:	5
Capacitor in µF:	20

8-30

Voltage in V:	230
Power in Watt:	2.200
Max. flow in liters / min:	120
Max. increaseHeight in m:	50
Number of fans:	5
Capacitor in µF:	20

8-50

Voltage in V:	230
Power in Watt:	2.700
Max. flow in liters / min:	180
Max. increaseHeight in m:	53
Number of fans:	5
Capacitor in µF:	25

MATERIAL

Housing:	Gemoffeld staal
Breaktank:	HPDE
Drinking water connection:	Messing
Supply pump connection:	Messing
Connection Pressure side:	RVS
Fans:	RVS
Pump housing:	RVS
Motor housing:	RVS
Air separator and guide wheel:	PPO (noryl)
Electro cable pump:	3 aderig 1,00 mm ² H07Rn-F

TECHNICAL DIAGRAMS

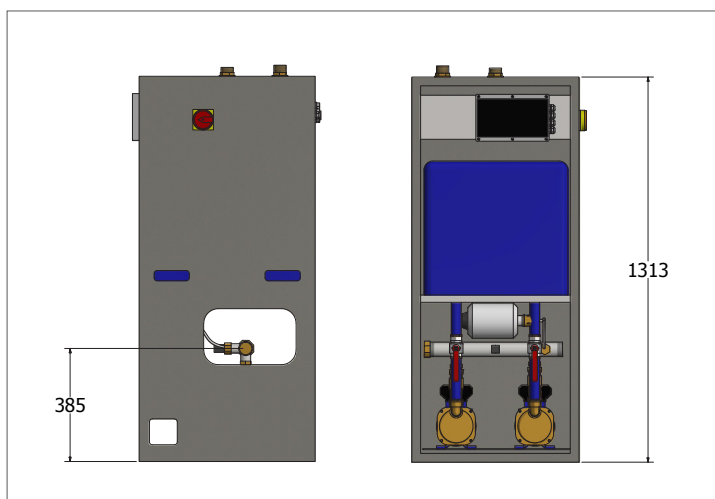
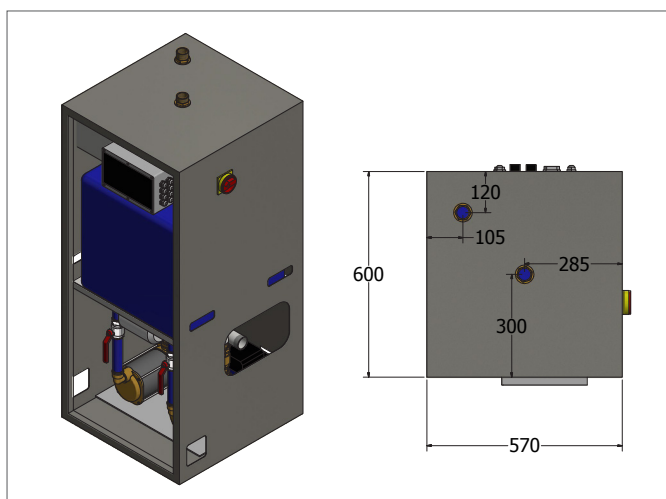

PUMP CHARACTERISTIC

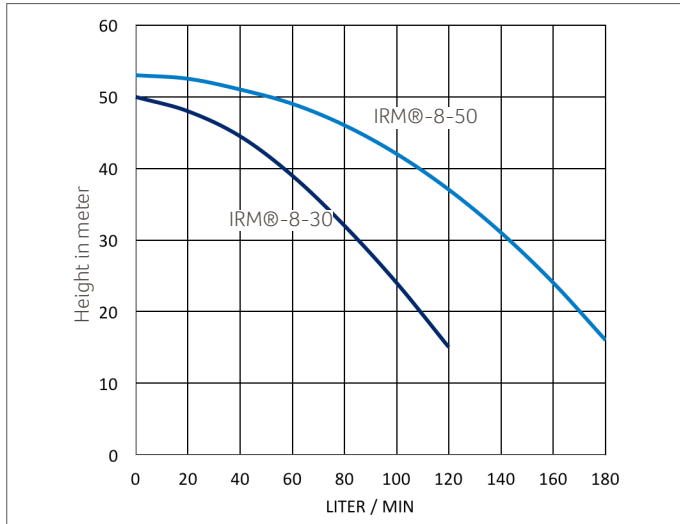

CONNECTION DIAGRAM

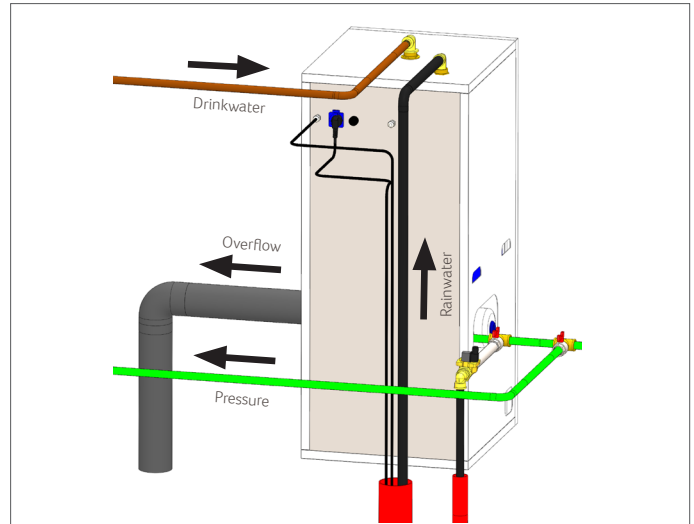

OPTIONS

Level sensor with 20 meters of cable
With this sensor it is possible to display the current water level in the rainwater tank on the control unit.

Automatic time-controlled filter cleaner 1"
Time-controlled filter cleaner enables automatic filter cleaning. The nozzle will clean the filter surface at freely adjustable times.

Water lock 1" including detection point
Always close the drinking water supply during an overflow alarm to prevent water loss. This makes it possible to mount the device without connecting the overflow.

Backflow sensor
This registers an alarm signal from the sewer level, after which the IRM@ system switches to drinking water and activates an alarm signal.

Antihevelset

In places where the break tank is lower than the rainwater tank, an anti-hull set must be placed in the feed pump line.

Supply pump

Supply pump provides the supply of rainwater to the Water Manager. Type depends on desired flow rate and on the distance (> 15m) and the Höhe (> 3m) between the Watermanager and rainwater well.

Pressure vessel

Pressure vessels give the switching behavior of the pumps a calmer character, which benefits the life and energy consumption of the pumps.

SCOPE OF DELIVERY

Product consists of: IRM@-8-30 Watermanager / IRM@-8-50 Watermanager and installation instructions.

ORDERING INFORMATION

Art nr	NAME	PG
402602	IRM@-8 Watermanager 8-30	4
402603	IRM@-8 Watermanager 8-50	4
402711	Level sensor with 20 meters of cable	4
401251	Automatic time-controlled filter cleaner 1"	4
402125	Water lock 1" including detection point	4
401158	Backflow sensor	4
402713	Anti-mist set IRM@ 8	4

For supply pumps see the GEP specification sheet
For pressure vessels see the GEP specification sheet

